



QUALITY ASSURANCE SPECIFICATIONS™

SFI SPECIFICATION 56.1

EFFECTIVE: FEBRUARY 18, 2008*

PRODUCT: NASCAR Dashboard and Other Carbon Fiber Components

1.0 GENERAL INFORMATION

- 1.1 This SFI Specification establishes uniform test procedures and minimum standards for evaluating and determining performance capabilities for NASCAR Dashboard and Other Carbon Fiber Components used by individuals engaged in competitive motorsports.
- 1.2 The procedures, test evaluations and standards contained herein, are intended only as minimum guidelines for construction and evaluation of products. Certification that products meet such minimum standards is made by the product manufacturer and products are not certified, endorsed or approved by SFI under this program.
- 1.3 Use of the "This Manufacturer Certifies That This Product Meets SFI Specification 56.1" logo/designation, the authorized artwork style, or conventional lettering by a manufacturer, on a subject product, is intended only to indicate that the manufacturer of the product has represented that they have submitted the product to the recommended tests, with positive results, in compliance with the standards established herein.
- 1.4 This SFI Specification requires a demonstration that the product of a manufacturer meets or exceeds the requirements when the manufacturer enters the program; and on a periodic basis thereafter. Any manufacturer may participate in the program by providing NASCAR Dashboard and Other Carbon Fiber Components that meet or exceed the SFI Specification 56.1 test standards, by complying with the requirements of the SFI Specification 56.1 program, and by signing a licensing agreement with the SFI Foundation, Inc.

- 1.5 Compliance with this specification is entirely voluntary. However, when a manufacturer provides NASCAR Dashboard and Other Carbon Fiber Components in compliance with all requirements of the SFI Specification 56.1 and enters into the licensing agreement with the SFI Foundation, Inc., they may certify that compliance with such standards is in accordance with the guidelines established herein.
- 1.6 Manufacturers wishing to participate in the program, in addition to the other requirements of this specification, must label each of their products with the manufacturer's name, trademark or symbol as well as the date of manufacture of the product.
- 1.7 No manufacturer may display the SFI logo/designation on their product unless the manufacturer has signed a licensing agreement with SFI and has successfully complied with all the requirements of this specification and the self-certification program.

2.0 DEFINITIONS

- 2.1 Race car dashboards and carbon fiber components are defined as those products used in NASCAR type race vehicles where fire resistance is essential.
- 2.2 Flame time is the length of time measured from the point when the flame is removed until no visible flame or visible glowing of the sample exists in seconds.
- 2.3 Burn length is the measured length of material burned away or charred from the original sample length after the flame on the sample has ceased and cooled. Discolorations shall not be considered as part of burn length.

3.0 CONSTRUCTION

NASCAR Dashboard and Other Carbon Fiber Components may be constructed of any appropriate material and manufacturing method as long as all the requirements of this spec are met.

4.0 MODEL CLASSIFICATION

The major factors for model determination are materials and construction process. A variation of any of these parameters is considered a model change and must be tested to initial design requirements.

5.0 TESTING

5.1 VERTICAL BURN TEST

5.1.1 SAMPLES

- A. Three (3) test samples shall be cut from a fabricated part or a portion simulating a cut section such as a specimen cut from a flat sheet of the material. Each sample to be 3.0 ± 0.10 inches wide by 12.0 ± 0.20 inches long. The sample thicknesses should be the minimum thickness of the product to be qualified.
- B. Edges must be fine sanded to remove burrs, saw marks and residual filaments.

5.1.2 CONDITIONING

Test samples must be conditioned for at least 24 hours at $70^{\circ} \pm 4^{\circ}$ F and $50\% \pm 5\%$ relative humidity before testing. Samples shall be tested within one hour after conditioning is complete.

5.1.3 APPARATUS

- A. The vertical tests must be conducted in a draft free cabinet in accordance with Federal Test Method Standard 191 Model 5903 or equivalent.
- B. The sample must be mounted in a metal frame so that the two long edges and the upper short edge are held securely in a vertically adjustable stand.
- C. The burner shall be a Bunsen or Tirrill type tube length 3.75 ± 0.25 inches and inside diameter of $0.375 +0.06/-0.00$ inch.
- D. Timer – Stop watch or other suitable timing device capable of timing within 1 second.
- E. Cotton – Absorbent 100% cotton placed on the bottom of the cabinet under the sample 12 inches from the bottom edge of the sample.

5.1.4 PROCEDURE

- A. All three samples must be tested and results averaged.
- B. The samples must be supported by the metal frames in the draft free cabinet with the long sides vertical and with the lower edge 0.75 inch above the top edge of the burner. Cotton shall be placed per Paragraph 5.1.3E.
- C. The burner shall be adjusted to maintain a flame height of 1.5 inches. The flame temperature measured by a calibrated thermocouple pyrometer at flame center shall be 1550°F minimum.
- D. The flame shall be applied to the lower edge of the sample for 15 seconds and then removed. If drippings affect the flame, the burner may be angled up to 45° with vertical to maintain the flame integrity.
- E. Total burn length shall be measured and recorded.
- F. Flame time shall be measured after the burner is removed from below the sample.
- G. Drippings from the sample shall be measured for flame time separately.
- H. After all three samples have been tested as above, the values of E, F, and G above shall be averaged and recorded separately.

5.2 HORIZONTAL BURN TEST

5.2.1 SAMPLES

- A. Three (3) test samples shall be cut from a fabricated part or a portion simulating a cut section such as a specimen cut from a flat sheet of the material. Each sample to be 3.0 ± 0.10 inches wide by 12.0 ± 0.20 inches long. The sample thicknesses should be the minimum thickness of the product to be qualified.
- B. Edges must be fine sanded to remove burrs, saw marks and residual filaments.

5.2.2 CONDITIONING

Test samples must be conditioned for at least 24 hours at $70^{\circ} \pm 4^{\circ}$ F and $50\% \pm 5\%$ relative humidity before testing. Samples shall be tested within one hour after conditioning is complete.

5.2.3 APPARATUS

- A. The horizontal tests must be conducted in a draft free cabinet in accordance with Federal Test Method Standard 191 Model 5906 or equivalent.
- B. The sample must be mounted in a metal support with the long sides horizontal and with the short sides inclined at 45° to the horizontal (See Figure 1). The metal frame on the long sides must be shorter than the sample such that at least 1.5 inches of the sample extends past the frame on the flame end.
- C. The burner shall be a Bunsen or Tirrill type tube length 3.75 ± 0.25 inches and inside diameter of $0.375 +0.06/-0.00$ inch.
- D. Timer – Stop watch or other suitable timing device capable of timing within 1 second.
- E. Wire gauze, 20 mesh (approximately 20 openings per inch) made with 0.016 inch diameter iron wire cut to a size to catch burning or glowing particles falling from the samples mounted per Figure 1.
- F. A pan of water shall be placed in the cabinet under the sample to contain any burning or hot particles that may drop during the test.

5.2.4 PROCEDURE

- A. All three samples must be tested separately and results averaged.
- B. The samples must be supported horizontally in a draft free cabinet on the two long edges and the short edge away from the flame by a metal frame slightly shorter than the sample itself at a 45° angle with the burner positioned as shown in Figure 1.
- C. The burner shall be adjusted to maintain a flame height of 1.5 inches. The flame temperature measured by a calibrated thermocouple pyrometer at flame center shall be 1550° F minimum.

- D. The flame shall be applied to the lower corner of the sample for 15 seconds and then removed. If drippings affect the flame, the burner may be angled up to 45° with vertical to maintain the flame integrity.
- E. Total burn length shall be measured and recorded.
- F. Flame time shall be measured after the burner is removed and the sample is cool.
- G. After all three samples have been tested as above, the values of E and F above shall be averaged and recorded separately.

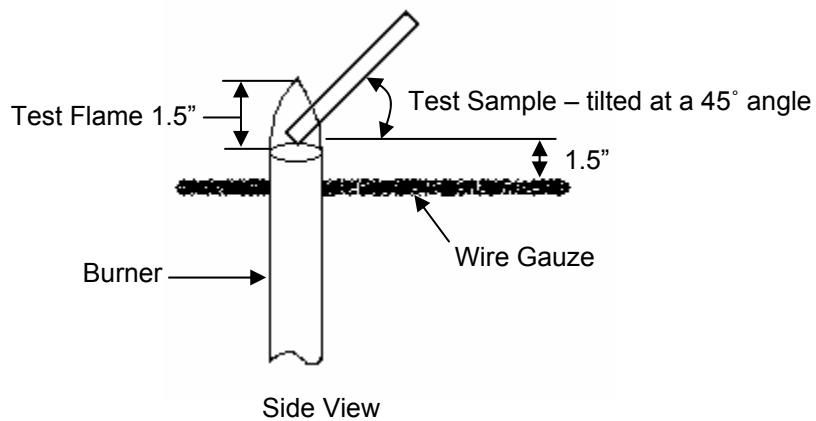
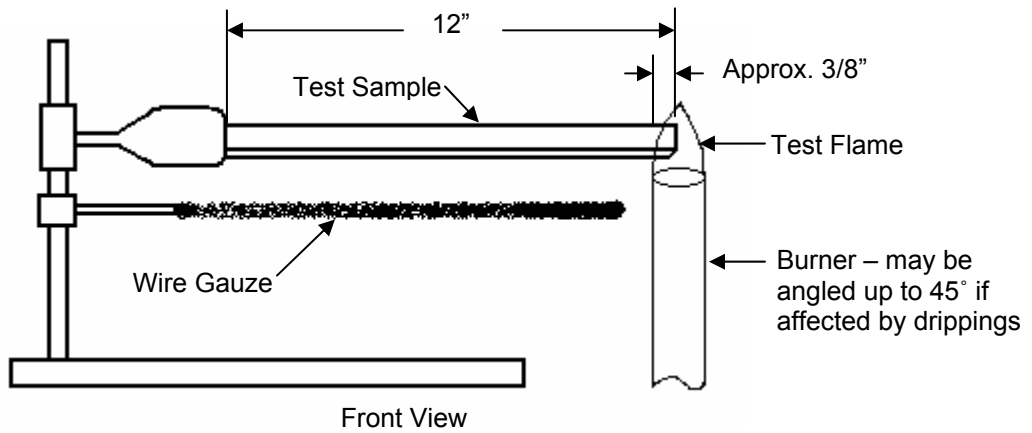

Figure 1
Test Fixture

6.0 PROOF OF COMPLIANCE

Manufacturers of carbon fiber products pertaining to this specification are required to provide the following information to enroll in this program:

6.1 TEST RESULTS

Test results shall be documented in a test report. If any of the following values are exceeded the test shall be considered a failure:

6.1.1 VERTICAL BURN TEST

- A) Average Total Burn Length measured per paragraph 5.1.4.E shall not exceed 6.0 inches with no single value greater than 6.5 inches.
- B) Average Flame Time measured per paragraph 5.1.4.F shall not exceed 15 seconds with no single value greater than 17 seconds.
- C) Average Flame Time of Drippings shall not continue to flame for more than 3.0 seconds after falling.

6.1.2 HORIZONTAL BURN TEST

- A) Average Total Burn Length measured per paragraph 5.2.4.E shall not exceed 6.0 inches with no single value greater than 7.0 inches.
- B) Average Flame Time measured per paragraph 5.2.4.F shall not exceed 15 seconds with no single value greater than 17 seconds.

7.0 TEST REPORTS

A separate test report, or set of test reports if required, shall be submitted for each product model. If more than one test facility is required to complete all necessary tests, then a separate test report shall be submitted from each one. A test report shall be submitted for each component, if tested separately. The test facility shall assign a unique number to each test report. This number along with the report date and page number shall appear on each page. Each test report shall include:

7.1 RELEVANT INFORMATION

- 7.1.1 Manufacturer's name, contact name, address and telephone number.
- 7.1.2 Name, address and telephone number of the test facility.
- 7.1.3 Name and signature of the responsible test supervisor.
- 7.1.4 Actual date of the test.
- 7.1.5 Specification number and effective date.
- 7.1.6 Product name, description and model designation.
- 7.1.7 Component name and description.

7.2 TESTS

Each test conducted shall be listed showing the test name, apparatus used, procedure used and test results obtained along with any other appropriate information.

7.3 AUTHENTICATION

Test reports shall be authenticated and stamped by a Professional Engineer who is registered in the state in which the testing is conducted. If necessary, SFI may allow an equivalent entity to provide authentication.

8.0 INITIAL DESIGN VALIDATION

To receive initial recognition from SFI as a participant in the SFI Specification 56.1 Program, the manufacturer must submit to SFI all information delineated in the Proof of Compliance section. This information shall be provided for each NASCAR Dashboard and Other Carbon Fiber Components model offered by the applicant that is to be included in the program. Any change in design, materials and/or methods of manufacturing not specifically excluded is considered a model change and, therefore, requires initial design validation.

9.0 PERIODIC REVALIDATION

Test reports with successful test results must be submitted to SFI at least once every 12 month period following the date of the initial design validation test for each model of NASCAR Dashboard and Other Carbon Fiber Components manufactured by the participant. If multiple test reports are required to obtain all test results, then the earliest test date shall be used to determine when the periodic revalidation reports are due. Also, SFI shall retain the option to conduct random audit reviews. SFI shall purchase the product on a commercial basis and test for compliance to the specification. The submitting manufacturer shall reimburse SFI for all audit costs.

10.0 CERTIFICATION OF COMPLIANCE

Upon demonstration of successful compliance with all the requirements of the specification and the self-certification program and upon entering the licensing agreement with SFI, the manufacturer may advertise, present and offer the NASCAR Dashboard and Other Carbon Fiber Components for sale with the representation that their product meets the SFI Specification 56.1. Continuing certification is contingent upon the following additional considerations: (1) the product shall be resubmitted for testing following any change in design, materials and/or methods of manufacturing not specifically excluded, and (2) periodic revalidation test reports are submitted when due to SFI.

11.0 CONFORMANCE LABELS

The conformance label is a punch out sticker purchased from SFI by the manufacturer, which shall be placed on each NASCAR Dashboard or Other Carbon Fiber Component. Holes (1/8" diameter) shall be punched in each sticker indicating the month and year the component is manufactured. Besides placing the label on the component, the serial number of the label along with the date shall be permanently marked on the component. The conformance label and permanently marked serial number shall be placed on the driver side left front corner of the dashboard in a location easily readable by technical inspectors, i.e., visible through the windshield from outside the car. The serial number should appear on the customer invoice (if applicable) to aid in identification and tracking.

12.0 DECERTIFICATION

Participating manufacturers are subject to decertification when not in compliance with the requirements of this program or when their products are not in compliance with the requirements of this specification. Decertification will provide SFI the right to effect any and all remedies which are available to SFI in the licensing agreement.

13.0 APPEAL PROCEDURE

In the event of decertification, the manufacturer is entitled to an appeal of the decision of SFI. Requests for appeal must be received by SFI no later than thirty days following receipt of the notice of decertification. Appeals of such decisions will be heard at the next meeting of the Board of Directors of SFI.

14.0 STATEMENT OF LIMITATIONS

Testing procedures and/or standards contained in this specification are intended for use only as a guide in determining compliance with the minimum performance requirements as defined herein. The granting and assignment of the "This Manufacturer Certifies That This Product Meets SFI Specification 56.1" logo/designation is in no way an endorsement or certification of product performance or reliability by SFI. SFI, its officers, directors and/or members assume no responsibility, legal or otherwise, for failure or malfunctions of a product under this program.

15.0 COSTS

All costs involved in this program will be absorbed by the submitting manufacturer.

16.0 COMPLIANCE PERIOD

As this specification is revised to reflect changes in technology and/or field conditions, to remain current, participating manufacturers in the SFI Specification 56.1, Dashboard and Other Carbon Fiber Components, Program, must demonstrate full compliance with the requirements of this specification within ninety (90) days of the latest effective date.

* Original Issue: February 18, 2008