



QUALITY ASSURANCE SPECIFICATIONS™

SFI SPECIFICATION 17.1

EFFECTIVE: JUNE 26, 2020*

PRODUCT: On Board Fire Suppression Systems

1.0 GENERAL INFORMATION

- 1.1 This SFI Specification establishes uniform test procedures and minimum standards for evaluating and determining performance capabilities for On Board Fire Suppression Systems used by individuals engaged in competitive motorsports.
- 1.2 The procedures, test evaluations and standards contained herein, are intended only as minimum guidelines for construction and evaluation of products. Certification that products meet such minimum standards is made by the product manufacturer and products are not certified, endorsed or approved by SFI under this program.
- 1.3 Use of the "This Manufacturer Certifies That This Product Meets SFI Specification 17.1" logo/designation, the authorized artwork style, or conventional lettering by a manufacturer, on a subject product, is intended only to indicate that the manufacturer of the product has represented that they have submitted the product to the recommended tests, with positive results, in compliance with the standards established herein.
- 1.4 This SFI Specification requires a demonstration that the product of a manufacturer meets or exceeds the requirements when the manufacturer enters the program; and on a periodic basis thereafter. Any manufacturer may participate in the program by providing On Board Fire Suppression Systems that meet or exceed the SFI Specification 17.1 test standards, by complying with the requirements of the SFI Specification 17.1 program, and by signing a licensing agreement with the SFI Foundation, Inc.

- 1.5 Compliance with this specification is entirely voluntary. However, when a manufacturer provides On Board Fire Suppression Systems in compliance with all requirements of the SFI Specification 17.1 and enters into the licensing agreement with the SFI Foundation, Inc., they may certify that compliance with such standards is in accordance with the guidelines established herein.
- 1.6 Manufacturers wishing to participate in the program, in addition to the other requirements of this specification, must label each of their products with the manufacturer's name, trademark or symbol as well as the date of manufacture of the product.
- 1.7 No manufacturer may display the SFI logo/designation on their product unless the manufacturer has signed a licensing agreement with SFI and has successfully complied with all the requirements of this specification and the self-certification program.

2.0 DEFINITIONS

- 2.1 An On Board Fire Suppression System shall provide fire suppression within a racing vehicle to primarily protect the occupant(s) and secondarily to minimize damage to the vehicle itself.
- 2.2 Agent: The fluid or gas used to suppress/extinguish a fire.
- 2.3 Cylinder: The container for the agent.
- 2.4 Metal Connecting Tubes: The transport medium for the agent from the cylinder to the fire protection area.
- 2.5 Actuating Mechanism: The device used to initiate the delivery of the agent from the cylinder.
- 2.6 Class B Fires: Fires in flammable/combustible liquids.
- 2.7 On Board Fire Suppression Systems shall be inspected for recertification at least every two years after the date of original certification or as specified by the certifying manufacturer. When a unit is determined to be acceptable for continued service, a new conformance label marked with the inspection date shall be used. In-field recertification is permitted, but ONLY by the original manufacturer or its authorized agent. Mailing of certification labels to customers is strictly prohibited. Systems shall have a maximum field service life of 6 years from the original date of installation. At the end of the 6-year period, all systems must be returned to the manufacturer or a certified recycling service center for lawful disassembly, recycling and

decommissioning. No system may be refilled more than 6 times during its 6-year field service life.

- 2.8 Any On Board Fire Suppression System pertaining to this specification shall remain as constructed and tested by the original manufacturer and not modified. Each manufacturer must provide some means by which to indicate that the cylinder was filled with agent by the original manufacturer. Cylinders may not be filled or refilled by anyone other than the original manufacturer.
- 2.9 On Board Fire Suppression Systems certified to this specification must be installed according to the system manufacturer's instructions.

3.0 CONSTRUCTION

3.1 TYPE OF AGENT

The agent shall be capable of suppressing a Class B fire, defined by this standard as a special hazard. Acceptable agents must be Environmental Protection Agency (EPA) accepted. Dry chemical and carbon dioxide (CO₂) are not acceptable as agents under the requirements of this standard. Halon agents are not acceptable as of January 1, 2008.

3.2 MOUNTING

Cylinder(s), nozzles, tubing, cables and actuating mechanism(s) shall be located and structurally mounted per certifying manufacturer's requirements and include information such as installation plans and schematics, listed in a technical manual format and be available for inspection at each racing event. The cylinder(s) shall be placed such that they will not be able to contact the race track surface at any time and when cylinders are mounted in any position, pressure gauges must be visible for inspection.

3.3 SYSTEM MAKE-UP

Either a single cylinder or multiple cylinder system may be used. In the case of multiple cylinders, the manufacturer's instructions for separate actuation and distribution hardware shall be followed. Also, a multiple cylinder system may rely on the activation of one cylinder to cause the activation of the second cylinder.

3.4 ACTUATING MECHANISM

All On Board Fire Suppression Systems shall have a manual, pneumatic, electronic or electrical actuating mechanism operable by the occupant(s). Pneumatic, electronic or electrical actuating mechanisms must have a back-up manual actuating mechanism.

3.5 MARKING OF CYLINDERS

It is required that all suppression systems be designed, manufactured and tested in accordance with 49 CFR, 173.309. Except for cylinders without stored pressure, cylinders must meet the following specifications: DOT39, DOT3AL, DOT 4B360, DOT 4DS and/or TC 3ALM, DOT 4E260 and ISO 7866. Gross weight, tare weight values in pounds or grams shall be displayed on all cylinders. All labels must indicate the manufacturer's name and contact information, date of manufacture, contents (type of suppression agent), total cylinder weight, contents (agent) weight.

3.6 CYLINDER STATE

Extinguishers shall contain no less than 95% of the stated agent quantity. No system or cylinder shall include a manual agent on-off valve as the form of activation of the system. Cylinders may be made of steel or aluminum, capable of activation at a pressure less than the burst strength of the cylinder itself. All cylinders must have an indicator gauge readily visible for inspection and the gauge must be compatible with the agent used in the cylinder.

4.0 MODEL CLASSIFICATION

Any variation in the cylinder material, cylinder size, nozzles, agent, actuation mechanism or internal components is considered a model change and must be tested to initial design criteria. System manufacturer supplied metal fittings substituted for tested non-metal fittings, and system manufacturer approved substitute metal connecting tubes are not considered model changes.

5.0 TESTING

Test samples shall be fully processed new suppression systems which are representative of suppression systems currently produced or to be produced. All necessary mounting hardware along with mounting instructions shall be supplied by the certifying manufacturer and used/followed by the test lab for installation/mounting to the test fixture. All tests must be conducted utilizing the test fixture-installed tubing and nozzle locations unless the manufacturer intends to sell the system with larger or smaller tubing or hardware. In which case, the intended tubing and hardware must be used for testing. Test samples must be preconditioned for two (2) hours prior to testing. Sample cylinders must be temperature conditioned to 70°F ± 5°F before testing. Actual fire testing must be conducted within an indoor laboratory temperature of 70°F ± 15°F. All cylinders must be tested in a horizontal orientation.

5.1 SYSTEM AND AGENT PERFORMANCE

Each of the components parts (5 lbs. cylinder, two {2} nozzles, actuating system and metal connecting tubes) shall remain operational after being subjected to propane flames from a torch for 15 seconds. Operational shall be defined as discharging 95% of the suppression agent in the cylinder (when liquid agent ceases to exit the nozzles) in a minimum of 10 seconds, 60 seconds maximum.

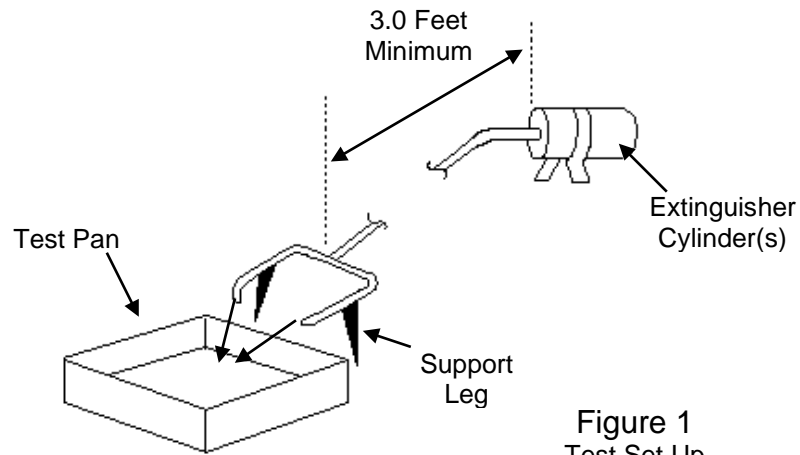

5.1.2 APPARATUS

A. The test pan shall be 19" x 19" x 5". The fuel to be tested shall be 24 ounces of racing gasoline.

B. The stationary nozzle location shall be arranged as illustrated in Figure 2 below.

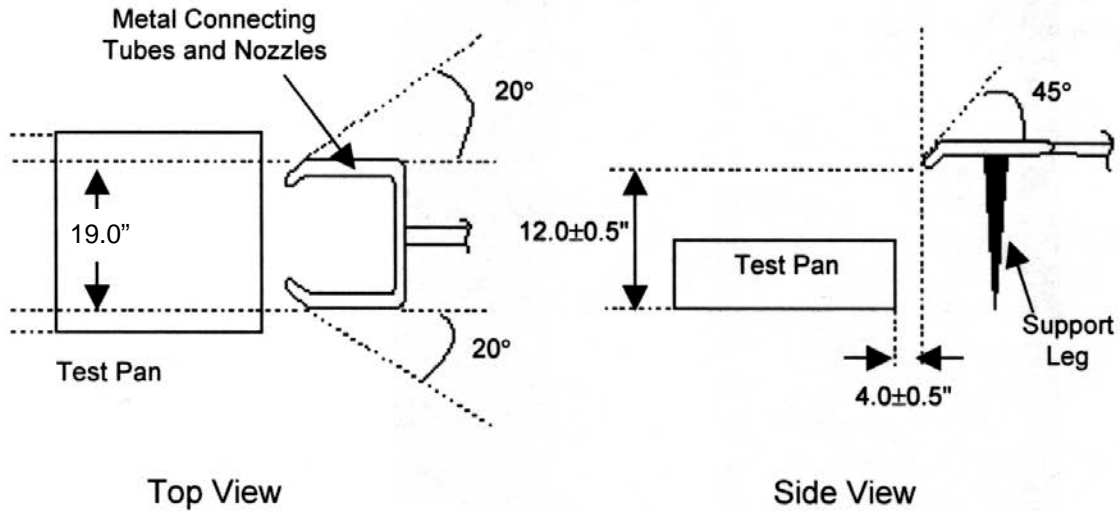

Figure 2

5.1.3 PROCEDURE

- A. Record the actual weight of agent (cylinder weight minus tare weight)
- B. Place the selected fuel in the pan.
- C. Ignite 24 ounces of racing fuel and allow to burn for 20 seconds.
- D. Trigger the actuation mechanism.
- E. Record the items listed (after preburn)
 - a. Record the time it takes to completely extinguish the pan fire in seconds.
 - b. Time to discharge 95% of the suppression agent in the cylinder (when liquid agent ceases to exit the nozzles).

5.2 SIMULATED VEHICLE FIRE EXTINGUISHMENT PERFORMANCE

5.2.1 SAMPLES

The test pan shall be 19" x 19" x 5". The fuel to be tested shall be racing gasoline. The system to be tested shall include one 5-lbs. cylinder with two (2) nozzles for the Rear Engine Configuration and one 10-lbs. cylinder with four (4) nozzles for the Front Engine Configuration. Other components to be tested shall be as specified by the manufacturer including size and type of nozzles, all mounting and connecting hardware and actuating mechanism(s). Both testing procedures 5.2.3.1 and 5.2.3.2 are required.

5.2.2 APPARATUS

5.2.2.1 ENGINE BOX SIMULATOR

Simulated engine box as illustrated in Figure 3 below.

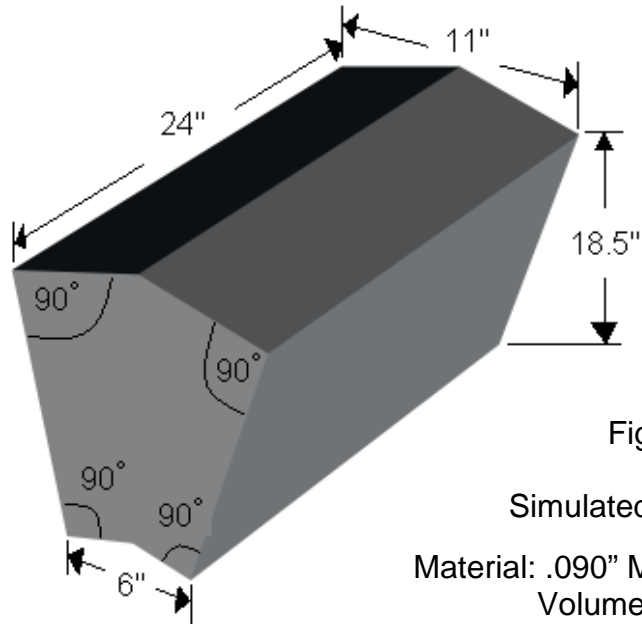

Figure 3

Simulated Engine Box

Material: .090" Mild Steel Minimum
Volume = 2.21 ft³

5.2.2.2 RACE CAR BODY SIMULATOR

Simulated race car body as illustrated in Figure 4 below.

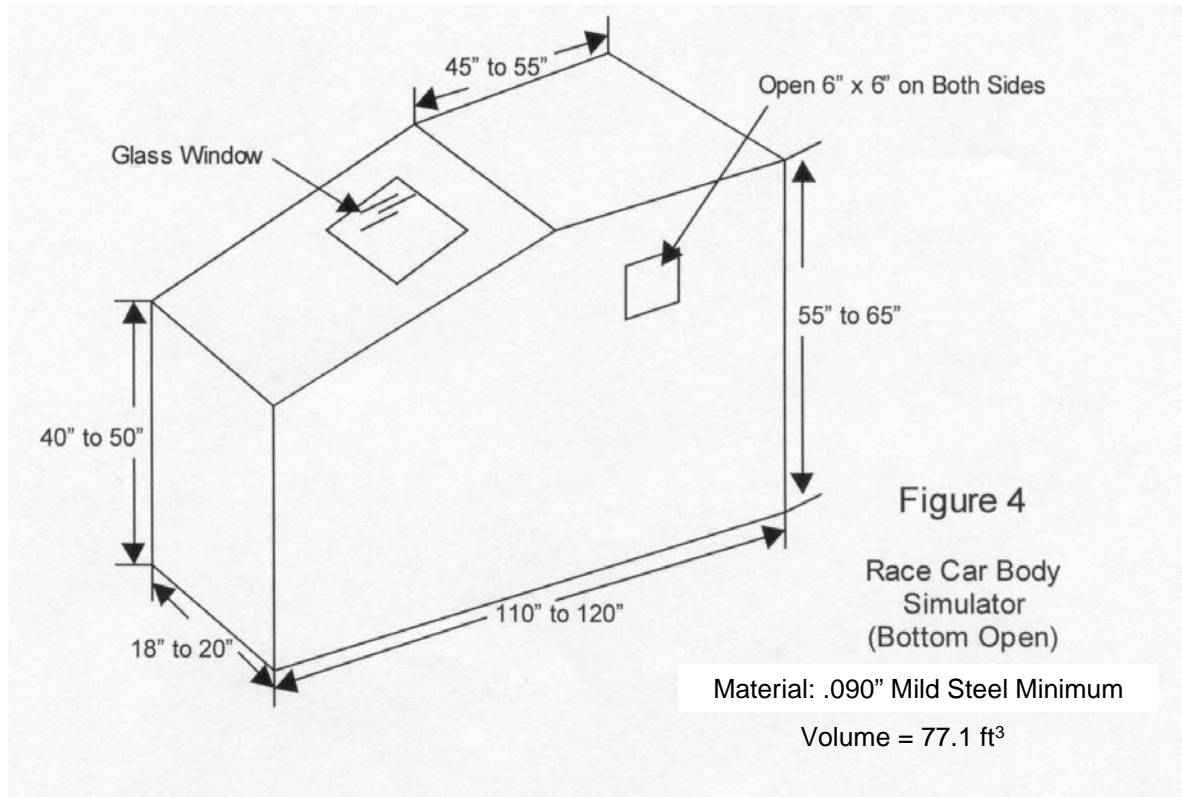

5.2.2.3 RACE CAR CHASSIS SIMULATOR

Simulated race car chassis as illustrated in Figure 5 below.

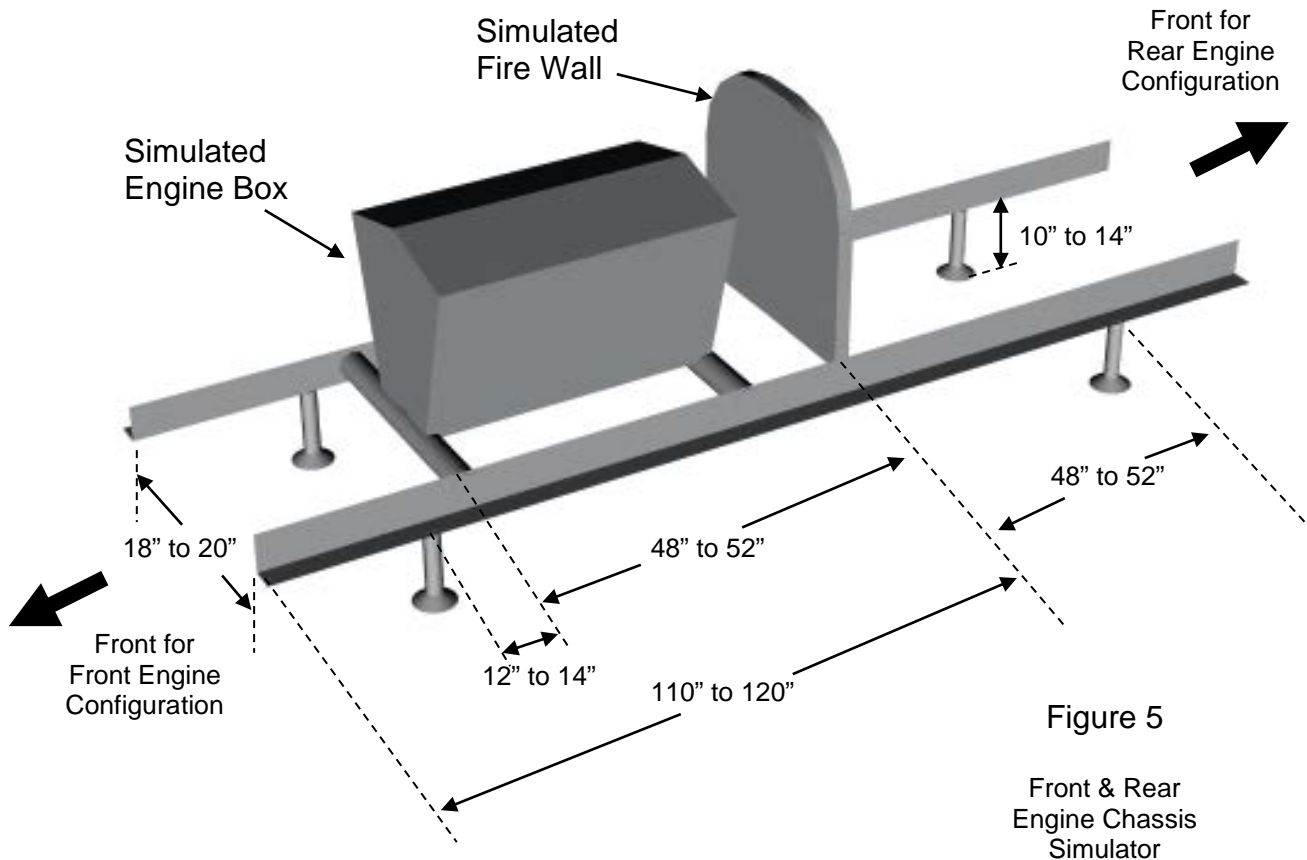

5.2.3 PROCEDURES

Sequence of testing procedures A through E may be altered if desired by manufacturer but must all be included before ignition.

5.2.3.1 FRONT ENGINE RACE CAR

- A. Place the Engine Box (Figure 3) on the Chassis (Figure 5).
- B. Attach the extinguisher system to the test fixture.
- C. Install the Body (Figure 4) over the Engine Box and onto the Chassis in proper front engine configuration.
- D. Center the pan under the Engine Box.

- E. Place 24 ounces of racing fuel in the pan.
- F. Ignite the fuel and allow to burn for 20 seconds. Activate two (2) fans of 1,150 cfm each from a distance of 10 feet and spaced 22 inches apart.
- G. Trigger the actuation mechanism.
- H. Record the items listed (after preburn)
 - a. Record the time it takes to completely extinguish the fire in seconds.
 - b. Time to discharge 95% of the suppression agent in the cylinder (when liquid agent ceases to exit the nozzles).

5.2.3.2 REAR ENGINE RACE CAR

- A. Attach the extinguisher system to the test fixture.
- B. Install the Body (Figure 4) onto the Chassis in proper rear engine configuration.
- C. Center the pan under the Body.
- D. Place 24 ounces of racing fuel in the pan.
- E. Ignite the fuel and allow to burn for 20 seconds. Activate two (2) fans of 1,150 cfm each from a distance of 10 feet and spaced 22 inches apart.
- F. Trigger the actuation mechanism.
- G. Record the items listed (after preburn)
 - a. Record the time it takes to completely extinguish the fire in seconds.
 - b. Time to discharge 95% of the suppression agent in the cylinder (when liquid agent ceases to exit the nozzles).

5.3 AUTOMATIC THERMOSTAT ACTUATOR PERFORMANCE

5.3.1 SAMPLES

The test pan shall be 19" x 19" x 5". The fuel to be tested shall be racing gasoline. The system to be tested shall include one 10-lbs. cylinder and one automatic thermostat device for each testing procedure. Other components to be tested shall be as specified by the manufacturer including size and type of device, all mounting and connecting hardware and actuating mechanism(s). Both testing procedures 5.3.3.1 and 5.3.3.2 are required to be performed. When installed on the test fixture, the automatic thermostat device shall be located within 2 inches of the rear firewall.

5.3.2 APPARATUS

5.3.2.1 RACE CAR BODY REAR AREA SIMULATOR

Simulated race car body as illustrated in Figure 6 below.

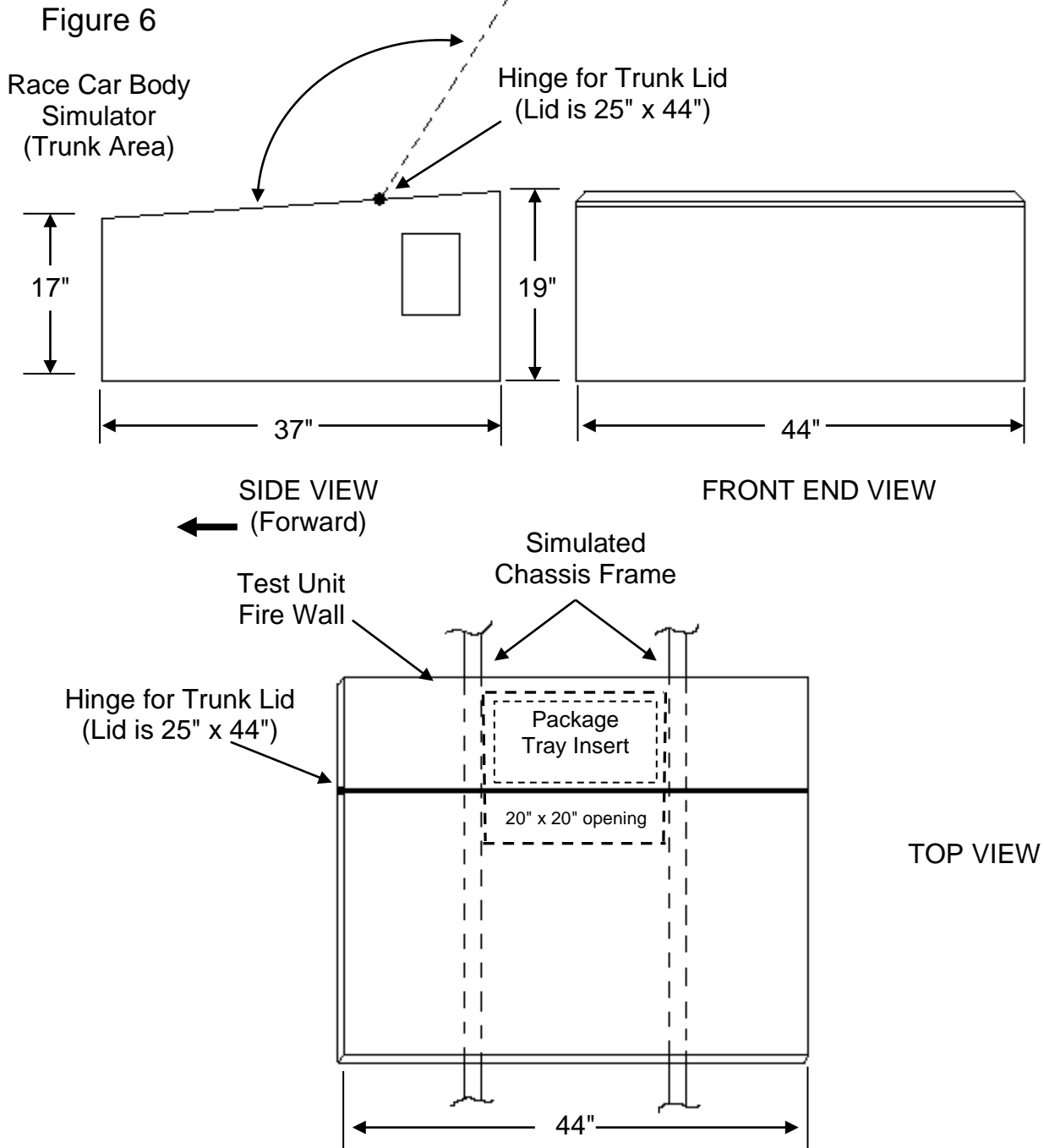

5.3.3 PROCEDURES

Sequence of testing procedures A through D may be altered if desired by manufacturer but must all be included before ignition.

5.3.3.1 OPEN TRUNK LID CONFIGURATION

- A. Attach the extinguisher system to the test fixture.
- B. Install the Race Car Body Rear Simulator (Figure 6) on the Engine Chassis (Figure 7 below shows new location) with the trunk lid in the open position and side windows closed.
- C. Center the pan in the proper location (Figure 7).
- D. Place 24 ounces of racing fuel in the pan.
- E. Ignite the fuel. Activate two (2) fans of 1,150 cfm each from a distance of 10 feet and spaced 22 inches apart.
- F. Record the items listed:
 - a. Response time for automatic activation of agent.
 - b. Record the time it takes to completely extinguish the fire in seconds.
 - c. Time to discharge 95% of the suppression agent in the cylinder (when liquid agent ceases to exit the nozzle).

Figure 7

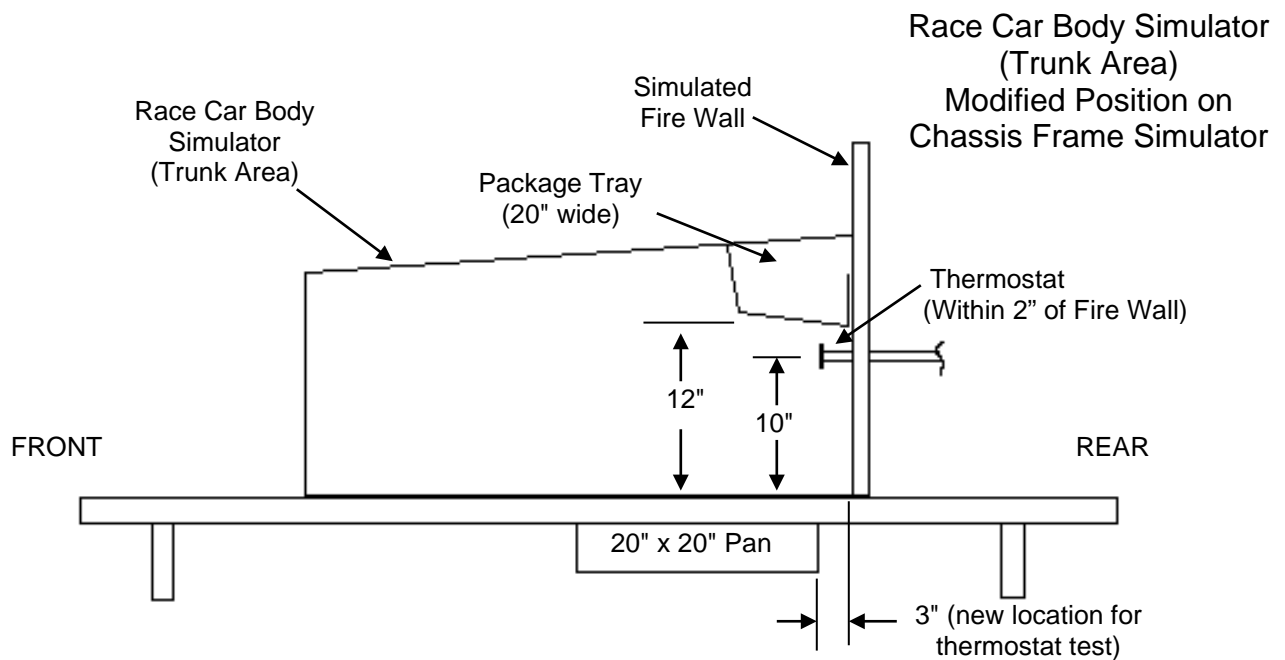

5.3.3.2 CLOSED TRUNK LID CONFIGURATION

- A. Attach the extinguisher system to the test fixture.
- B. Install the Race Car Body Rear Simulator (Figure 6) on the Engine Chassis (Figure 7 below shows new location) with the trunk lid in the closed position and windows vented.
- C. Center the pan in the proper location (Figure 7).
- D. Place 24 ounces of racing fuel in the pan.
- E. Ignite the fuel. Activate two (2) fans of 1,150 cfm each from a distance of 10 feet and spaced 22 inches apart.
- F. Record the items listed:
 - a. Response time for automatic activation of agent.
 - b. Record the time it takes to completely extinguish the fire in seconds.
 - c. Time to discharge 95% of the suppression agent in the cylinder (when liquid agent ceases to exit the nozzle).

6.0 PROOF OF COMPLIANCE

On Board Fire Suppression System manufacturers are required to provide the following information to enroll in this program:

6.1 TEST RESULTS

Test results shall be documented in a test report.

6.1.1 SYSTEM PERFORMANCE

The system shall extinguish the test fire in 10 seconds and shall discharge 95% of the suppression agent in the cylinder (when liquid agent ceases to exit the nozzles) in the required time with no re-ignition.

6.1.2 SIMULATED VEHICLE (FRONT AND REAR ENGINE)

The system shall extinguish the test fire in 10 seconds or less for rear engine car configurations and 20 seconds or less for front engine car configurations with no re-ignition.

6.1.3 AUTOMATIC THERMOSTAT ACTUATOR PERFORMANCE (OPEN AND CLOSED TRUNK CONFIGURATION)

The automatic thermostat actuator shall activate the system within 15 seconds maximum. The system shall extinguish the test fire in 10 seconds and shall discharge 95% of the suppression agent in the cylinder (when liquid agent ceases to exit the nozzles) in 10 seconds minimum, 60 seconds maximum with no re-ignition.

7.0 TEST REPORTS

A separate test report, or set of test reports if required, shall be submitted for each product model. If more than one test facility is required to complete all necessary tests, then a separate test report shall be submitted from each one. A test report shall be submitted for each component, if tested separately. The test facility shall assign a unique number to each test report. This number along with the report date and page number shall appear on each page. Each test report shall include:

7.1 RELEVANT INFORMATION

7.1.1 Manufacturer's name, contact name, address and telephone number.

- 7.1.2 Name, address and telephone number of the test facility.
- 7.1.3 Name and signature of the responsible test supervisor.
- 7.1.4 Actual date of the test.
- 7.1.5 Specification number and effective date.
- 7.1.6 Product name, description and model designation. Including:
 - A. Maximum/Minimum operating temperatures
 - B. Valid MSDS
- 7.1.7 Component name and description.
- 7.1.8 Photographs of each submitted system.

7.2 TESTS

Each test conducted shall be listed showing the test name, apparatus used, procedure used and test results obtained along with any other appropriate information.

7.3 AUTHENTICATION

Test reports shall be authenticated and stamped by a Professional Engineer who is registered in the state in which the testing is conducted. If necessary, SFI may allow an equivalent entity to provide authentication.

8.0 INITIAL DESIGN VALIDATION

To receive initial recognition from SFI as a participant in the SFI Specification 17.1 Program, the manufacturer must submit to SFI all information delineated in the Proof of Compliance section. This information shall be provided for each On Board Fire Suppression System model offered by the applicant that is to be included in the program. Any change in design, materials and/or methods of manufacturing not specifically excluded is considered a model change and, therefore, requires initial design validation.

9.0 PERIODIC REVALIDATION

Test reports with successful test results must be submitted to SFI at least once every 48 month period following the date of the initial design validation test for each model of On Board Fire Suppression System manufactured by the participant. If multiple test reports are required to obtain all test results, then the earliest test date shall be used to determine when the periodic revalidation reports are due.

10.0 CERTIFICATION OF COMPLIANCE

Upon demonstration of successful compliance with all the requirements of the specification and the self-certification program and upon entering the licensing agreement with SFI, the manufacturer may advertise, present and offer the On Board Fire Suppression Systems for sale with the representation that their product meets the SFI Specification 17.1. Continuing certification is contingent upon the following additional considerations: (1) the product shall be resubmitted for testing following any change in design, materials and/or methods of manufacturing not specifically excluded, and (2) periodic revalidation test reports are submitted when due to SFI.

11.0 CONFORMANCE LABELS

The conformance label is a sticker. A sticker shall be placed on each of the cylinders in the system. The serial number of the sticker should appear on the customer invoice to aid in identification and tracking.

12.0 DECERTIFICATION

Participating manufacturers are subject to decertification when not in compliance with the requirements of this program or when their products are not in compliance with the requirements of this specification. Decertification will provide SFI the right to effect any and all remedies which are available to SFI in the licensing agreement.

13.0 APPEAL PROCEDURE

In the event of decertification, the manufacturer is entitled to an appeal of the decision of SFI. Requests for appeal must be received by SFI no later than thirty days following receipt of the notice of decertification. Appeals of such decisions will be heard at the next meeting of the Board of Directors of SFI.

14.0 STATEMENT OF LIMITATIONS

Testing procedures and/or standards contained in this specification are intended for use only as a guide in determining compliance with the minimum performance requirements as defined herein. The granting and assignment of the "This Manufacturer Certifies That This Product Meets SFI Specification 17.1" logo/designation is in no way an endorsement or certification of product performance or reliability by SFI. SFI, its officers, directors and/or members assume no responsibility, legal or otherwise, for failure or malfunctions of a product under this program.

15.0 COSTS

All costs involved in this program will be absorbed by the submitting manufacturer.

16.0 COMPLIANCE PERIOD

As this specification is revised to reflect changes in technology and/or field conditions, to remain current, participating manufacturers in the SFI Specification 17.1, On Board Fire Suppression Systems, Program, must demonstrate full compliance with the requirements of this specification within ninety (90) days of the latest effective date.

*	Original Issue:	May 9, 1989
	Reviewed:	December 13, 1993
	Revised:	August 13, 2002
	Revised:	March 23, 2004
	Edited:	August 18, 2004
	Revised:	February 9, 2006
	Revised:	October 11, 2006
	Revised:	February 18, 2008
	Edited:	August 27, 2009
	Reviewed:	December 11, 2009
	Revised:	November 18, 2010
	Reviewed:	December 2, 2011
	Edited:	July 25, 2013
	Reviewed:	December 14, 2013
	Revised:	February 26, 2014
	Reviewed:	December 11, 2015
	Reviewed:	December 8, 2017
	Revised:	April 20, 2018
	Reviewed:	December 13, 2019
	Edited:	March 26, 2020
	Revised:	June 26, 2020